

NOBLES[®]
ENGINEERED BY TENNANT COMPANY

SCOUT™ 3

Manual walk-behind sweeper



Sweep smarter, not harder with the Nobles Scout-series sweepers

The Scout™ 3

It's efficient

Dual side brushes increase the sweeping path to 34 in / 870 mm, and a large 1.8 ft³ / 50 L hopper saves you trips to the dumpster, which gives you more time for cleaning.

It's flexible

The is well suited for indoor and outdoor cleaning. Manual operation makes it the perfect option for noise-sensitive environments.

It's durable

Major components field-proven in commercial applications for 10 years. Wrapped front bumper design helps prevent high-impact damage to body and side brushes.

It's easy

Simple, no-tool side brush adjustments and easy-to-use operation mean less time training and more time cleaning. The contoured handle is padded and ergonomically designed for optimal operator comfort.



Four no-nonsense features

- 1. Fully adjustable** dual side brushes clean corners and edges easily without changing directions and can be adjusted to your floor surface.



- 2. Large hopper** (1.8 ft³ / 50 L) reduces empties and is easy to remove, simplifying the cleaning process and increasing operator productivity.





TwinMax™ Sweeping Technology

Equipped with TwinMax sweeping technology, the Scout™ 3 cleans your floors in a single pass. The twin, counter-rotating brushes combine overthrow and direct sweeping principles to capture large and small debris with one machine.



TwinMax technology is designed for sweeping multiple surfaces in both indoor and outdoor environments, giving you maximum versatility for anytime, anywhere cleaning.

- 3. TennantTrue® brushes** are designed to fit your machine and deliver optimal cleaning performance. Chevron bristle pattern and TwinMax technology work together to pick up more debris in a single pass.



- 4. Ergonomically designed handle,** contoured and padded for operator comfort





Optimize cleaning performance with Tennant*True*®

Maximize the uptime and life of your Tennant equipment with Tennant*True* Parts and Service. Benefit from the unmatched knowledge of our team of over 400 factory-trained and certified Tennant Service technicians. Tennant*True* Parts are designed to fit your Tennant machine and deliver optimal cleaning performance. This helps reduce machine downtime and service calls. Depend on Tennant*True* to help you maximize the effectiveness of cleaning operations.

Tennant*True* Parts program includes Tennant, Nobles, Green Machines and Orbio cleaning equipment.

Engineered by Tennant Company, the Scout 3 is the smart, reliable choice for your no-nonsense cleaning needs.

Nobles
701 North Lilac Drive
Minneapolis, MN 55422
USA/Canada: +1.800.553.8033
Quebec: +1.800.361.9050
www.nobles.com
nobles@tennantco.com

Scout™ 3 Specifications		
Cleaning path	34 in	870 mm
Main brush length	20 in	500 mm
Main brush diameter	7.8 in	200 mm
Side brush diameter	13 in	320 mm
Debris hopper volume capacity	1.8 ft ³	50 L
Drive type	Belt	
Power system	Manual	
Product length	43 in	1092 mm
Product width	30 in	760 mm
Product height	55.7 in	416 mm
Product weight	66 lb	30 kg
Warranty	See your local representative for warranty information	

Specifications subject to change without notice.



Model Part No.:
1071116

Scout™ 3

TwinMax™ Technology

Manual Push Sweeper

TennantTrue® Parts

Barredora manual de empuje

Balayeuse autotractée manuelle

Operator and Parts Manual (EN)

Manual de funcionamiento y lista de componentes (ES)

Manuel de fonctionnement et liste des pièces (FR)

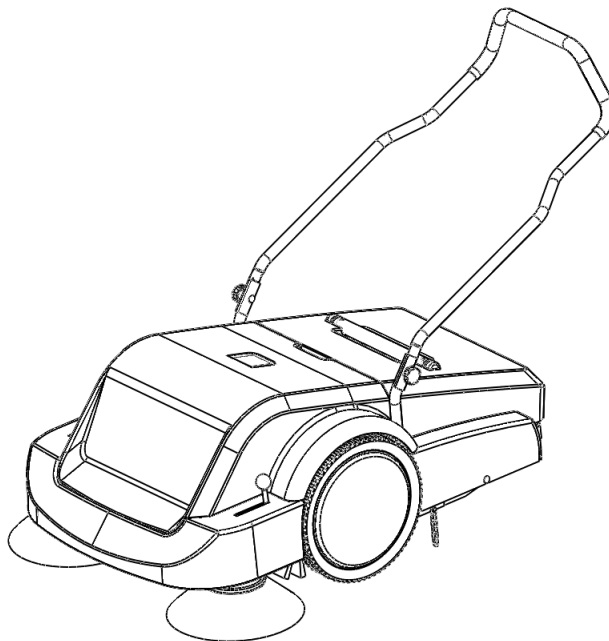

Introduction

This manual is furnished with each new model. It provides necessary operation and maintenance instructions and replacement parts information.



Read all instructions before using this machine.

Intended Use

This manual push sweeper is intended for commercial use, for example in buildings, warehouses, parking lots and sidewalks. It is designed for indoor and outdoor use and suitable for picking up dry, nonflammable dust and debris on dry hard floor and carpet surfaces. It is not suitable for wet surfaces or for picking up flammable or hazardous materials.

General Information

This machine will provide excellent service. However, the best results will be obtained at minimum costs if:

- The machine is operated with reasonable care.
- The machine is maintained regularly - per the machine maintenance instructions provided.
- The machine is maintained with manufacturer-supplied or equivalent parts.



Protect the Environment

Please dispose of packaging materials and used machine components in an environmentally safe way according to local waste disposal regulations.

Always remember to recycle.

Machine Data

Please fill out at time of installation for future reference.	
Model No. -	_____
Serial No. -	_____
Installation Date -	_____

Technical Specifications

Model	Scout 3
Length	1092 mm / 43 in
Width	760 mm / 30 in
Height	416 mm / 16,5 in
Weight	30 kg / 66 lb
Sweeping Path Width	900 mm / 35 in
Main Brush Width	500 mm / 20 in
Side Brush Diameter	320 mm / 13 in
Hopper Capacity	50 L / 53 qt
Productivity Rate (Net)	1740 m ² /hr / 18750 ft ² /hr

IMPORTANT SAFETY INSTRUCTIONS



This symbol warns the operator of hazards and unsafe practices which could result in severe personal injury or death.



WARNING - To reduce the risk of fire or Injury:

1. Use only as described in this manual.
2. Operators shall be adequately instructed on the use of this machine.
3. This machine is not intended for use by persons (including children) with reduced physical, sensory or mental capabilities, or lack of experience and knowledge.
4. Do not use on wet surfaces. This machine is for dry use only.
5. Do not pick up any type of liquid, hazardous dust or toxic materials.
6. Do not pick up anything that is burning or smoking, such as cigarettes, matches, or hot ashes.
7. Do not pick up objects such as cords, strings and wires that may entangle brush.
8. Do not use machine if not in proper operating condition.
9. Wear a dust mask, protective glasses and gloves in dusty environments.
10. Wear heavy gloves when removing sharp objects from hopper.
11. Use caution when lifting full hopper to avoid back strain.
12. Dispose of debris in an environmentally safe way.
13. Do not allow to be used as a toy. Close attention is necessary when used by or near children.
14. Keep hair, loose clothing, fingers, and all parts of body away from openings and moving parts.
15. Do not operate machine without hopper in place. Empty hopper of debris after each use.
16. Do not modify machine from its original design.
17. Keep children and unauthorized persons away from machine when in use.
18. Not do use machine to transport people or objects.
19. Do not wheel up or down stairs.
20. Use assistance when lifting machine.
21. Use only manufacturer-supplied or equivalent replacement parts.
22. Do not expose machine to rain or moisture. Store indoors.

SAVE THESE INSTRUCTIONS

Tennant Company
 PO Box 1452, Minneapolis, MN 55440 USA
 Phone: (800) 553-8033 or (763) 513-2850
 www.tennantco.com
 Original Instructions. Copyright © 2012 TENNANT Company.
 All rights reserved. Printed in Germany.
 Specifications and parts are subject to change without notice.

Introducción

Este manual se incluye en todos los modelos nuevos. Proporciona las instrucciones necesarias para su utilización y mantenimiento, así como información sobre los repuestos.



Lea todas las instrucciones antes de utilizar esta máquina.

Uso previsto

Este cortacésped manual está pensado para su uso comercial en edificios, almacenes, aparcamientos y aceras, entre otros. Está diseñado para interior y exterior y además recoge el polvo y los restos de suciedad secos y no inflamables de los suelos secos y alfombras. No es apropiado para superficies mojadas o para recoger materiales inflamables o peligrosos.

Información general

Esta máquina ofrece un funcionamiento excelente. Sin embargo, los resultados serán óptimos a un coste mínimo si:

- Maneja la máquina con un cuidado razonable.
- Realiza las operaciones de mantenimiento con regularidad, de acuerdo con las instrucciones adjuntas.
- Las operaciones de mantenimiento de la máquina se realizan con piezas suministradas por el fabricante o equivalentes.

Proteja el medio ambiente



Deseche el material de embalaje y los componentes usados de la máquina de forma segura para el medio ambiente, de acuerdo con las normas locales sobre desecho de residuos.



No olvide reciclar.

Datos de la máquina

Rellene esta ficha cuando realice la instalación, para utilizarla como referencia en el futuro.

Número de modelo - _____

Número de serie - _____

Fecha de instalación - _____

Especificaciones técnicas

Modelo	Scout 3
Longitud	1092 mm / 43"
Anchura	760 mm / 30"
Altura	416 mm / 16,5"
Peso	30 kg / 66 lb
Anchura de la pista de barrido	900 mm / 35"
Anchura del cepillo principal	500 mm / 20"
Diámetro del cepillo lateral	320 mm / 13"
Capacidad de la caja colectora	50 L / 53 cuartos
Productividad media (neta)	1740 m ² /hr / 18.750 pies ² /hr

Tennant Company
PO Box 1452, Minneapolis, MN 55440 USA
Teléfono: 001-800-553-8033 o 001-763- 513-2850
www.tennantco.com

Instrucciones originales. Copyright © 2012 TENNANT Company.
Todos los derechos reservados. Impreso en Alemania.
Las características técnicas y las piezas están sujetas a modificaciones sin previo aviso.

MEDIDAS DE SEGURIDAD



Este símbolo advierte al operario de los riesgos y hábitos peligrosos que podrían causar lesiones corporales graves o mortales.



ADVERTENCIA: para reducir el riesgo de incendios o lesiones:

1. Utilice la máquina únicamente tal y como se describe en este manual.
2. Los operarios deben recibir una instrucción adecuada con respecto al uso de esta máquina.
3. Esta máquina no está pensada para su uso por personas (incluyendo niños) con discapacidades físicas, sensoriales o mentales, o con falta de experiencia y conocimientos.
4. No utilice la máquina sobre superficies mojadas. La máquina debe usarse siempre en seco.
5. No recoja ningún tipo de líquido, polvo peligroso o materiales tóxicos.
6. No recoja restos ardiendo o humeantes como cigarrillos, cerillas o cenizas calientes.
7. No recoja objetos como cuerdas, hilos o cables que pudieran enredar el cepillo.
8. No utilice la máquina si no está en buenas condiciones de funcionamiento.
9. En ambientes con mucho polvo, protéjase con una mascarilla contra el polvo, gafas y guantes.
10. Protéjase con guantes cuando retire objetos punzantes del filtro.
11. Sea precavido cuando levante la caja colectora llena para evitar dolores de espalda.
12. Deshágase de los restos y desechos de forma respetuosa con el medio ambiente.
13. No permita que la máquina se utilice como un juguete. Preste especial atención cuando la máquina se esté utilizando en la proximidad de niños.
14. Mantenga las partes del cuerpo, como el cabello o los dedos y prendas sueltas alejadas de los orificios y piezas móviles.
15. No utilice la máquina sin estar la caja colectora instalada. Vacíe de desechos la caja colectora después de cada uso.
16. No modifique el diseño original de la máquina.
17. Mantenga a los niños y a las personas no autorizadas alejados de la máquina mientras esté en uso.
18. No utilice la máquina para transportar personas u objetos.
19. No baje ni suba escaleras utilizando las ruedas de la máquina.
20. Pida ayuda para levantar la máquina.
21. Utilice únicamente repuestos suministrados o aprobados por el fabricante.
22. No exponga la máquina a la lluvia o humedad. Guárdela en un lugar cerrado.

GUARDE ESTAS INSTRUCCIONES

Introduction

Ce manuel accompagne chaque nouveau modèle. Il fournit les instructions nécessaires au fonctionnement et à l'entretien, ainsi que les informations relatives au remplacement des pièces.



Lisez toutes les instructions avant d'utiliser cette machine.

Utilisation prévue

Cette balayeuse autotractée manuelle est destinée à un usage commercial (par exemple, dans les bâtiments, entrepôts, parcs de stationnement et trottoirs). Elle peut être utilisée à l'intérieur et à l'extérieur, et permet de ramasser la poussière sèche et non-inflammable, ainsi que les déchets sur sol dur et sec et les surfaces des moquettes. Elle ne peut pas être utilisée sur des surfaces humides ou pour le ramassage de matériaux inflammables ou toxiques.

Informations générales

Cette machine fournit d'excellents services. Toutefois, vous obtiendrez les meilleurs résultats, à moindre coût, si :

- La machine doit être manipulée avec précaution.
- La machine fait l'objet d'un entretien régulier conformément aux instructions d'entretien de ce manuel.
- L'entretien de la machine s'effectue avec les pièces fournies par le fabricant ou des pièces équivalentes.

Protection de l'environnement



Pour éliminer les matériaux d'emballage et les composants usagés de la machine en respectant l'environnement, respectez les réglementations locales en vigueur concernant la mise au rebut des déchets.



Pensez toujours à recycler.

Données de la machine

À remplir au moment de l'installation pour s'y référer ultérieurement.

N° de modèle - _____

N° de série - _____

Date d'installation - _____

Caractéristiques techniques

Modèle	Scout 3
Longueur	1092 mm / 45 in
Largeur	760 mm / 30 in
Hauteur	416 mm / 16,5 in
Poids	30 kg / 66 lb
Largeur de la trace de balayage	900 mm / 35 in
Largeur de la brosse principale	500 mm / 20 in
Diamètre de la brosse latérale	320 mm / 13 in
Capacité du bac à déchets	50 L / 53 qt
Taux de rendement (net)	1 740 m ² /h / 18 750 ft ² /h

Tennant Company
 PO Box 1452, Minneapolis, MN 55440 États-Unis d'Amérique
 Téléphone : (800) 553-8033 ou (763) 513-2850
 www.tennantco.com
 Instructions d'origine. Copyright © 2012 TENNANT Company.
 Tous droits réservés. Imprimé en Allemagne.
 Les caractéristiques et les pièces sont susceptibles d'être modifiées sans avis préalable.

CONSIGNES DE SÉCURITÉ IMPORTANTES



Ce symbole avertit l'opérateur de situations à risque ou de pratiques dangereuses pouvant provoquer des blessures graves, voire mortelles.



AVERTISSEMENT - Afin de réduire le risque d'incendie ou de blessure :

1. Utilisez la machine uniquement tel qu'indiqué dans ce manuel.
2. Les opérateurs devront avoir reçu une formation adéquate pour l'utilisation de cette machine.
3. Cette machine ne doit pas être utilisée par des (y compris des enfants) présentant des capacités physiques, sensorielles ou mentales limitées, ou ne possédant pas l'expérience et les connaissances requises.
4. N'utilisez pas la machine sur des surfaces humides. Cette machine ne doit être utilisée que dans des environnements secs.
5. Ne ramassez aucun type de liquide, poussières dangereuses ou matériaux toxiques.
6. Ne ramassez aucun objet incandescent ou générant de la fumée (tel que des cigarettes, allumettes ou cendres chaudes).
7. Ne ramassez pas d'objets susceptibles de se coincer dans la brosse (tel que des cordes, ficelles ou fils).
8. N'utilisez pas la machine si elle n'est pas en bon état de fonctionnement.
9. Portez un masque antipoussière, des lunettes protectrices et des gants dans les environnements poussiéreux.
10. Portez des gants renforcés pour ramasser les objets tranchants des bacs à déchets.
11. Lors du levage des bacs à déchets pleins, faites attention à ne pas vous faire un tour de reins.
12. Mettez les déchets au rebut de façon respectueuse de l'environnement.
13. Ne laissez personne utiliser la machine pour s'amuser. Faites particulièrement attention lorsque la machine est utilisée par ou à proximité d'enfants.
14. Éloignez des ouvertures et des pièces mobiles les cheveux, les vêtements amples, les doigts ou toute autre partie du corps.
15. N'utilisez pas la machine sans bac à déchets en place. Videz les déchets du bac après chaque utilisation.
16. Ne modifiez pas la conception d'origine de la machine.
17. Maintenez les enfants et les personnes non autorisées à l'écart de la machine pendant son utilisation.
18. N'utilisez pas la machine pour transporter des personnes ou des objets.
19. Ne faites pas rouler la machine dans les escaliers.
20. Faites-vous aider lors du levage de la machine.
21. Utilisez uniquement des pièces de rechange fournies par le fabricant ou équivalentes.
22. N'exposez pas la machine à la pluie ou à l'humidité. Entrez-la à l'intérieur.

CONSERVEZ CES INSTRUCTIONS

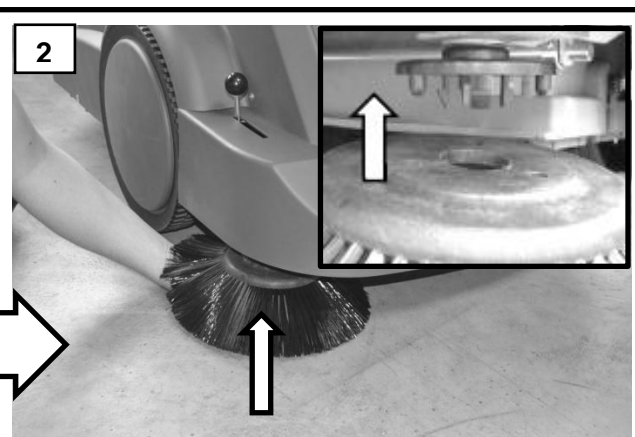
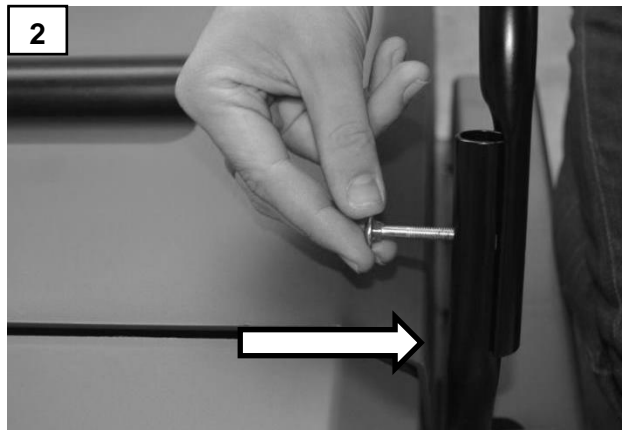
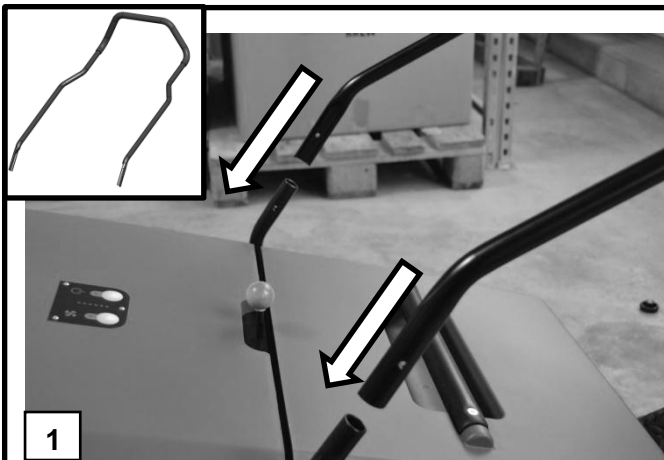
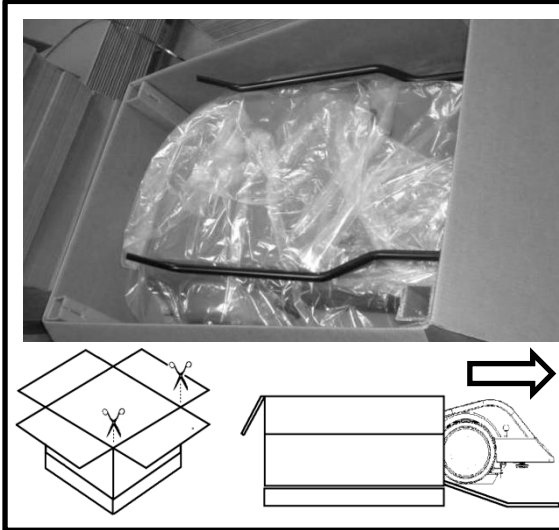

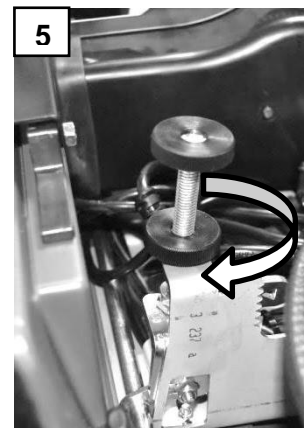
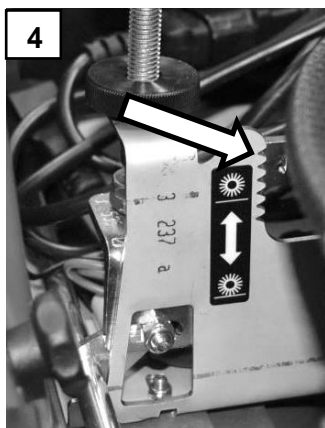
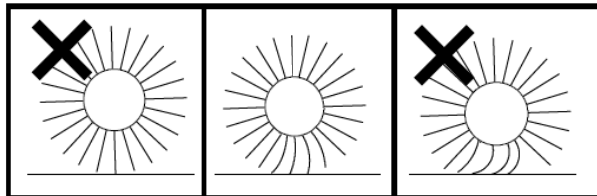
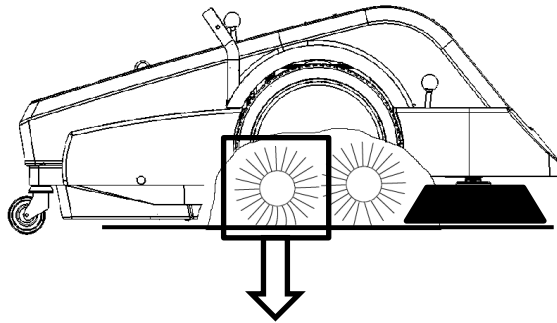
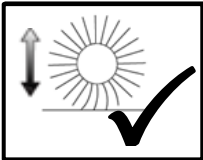

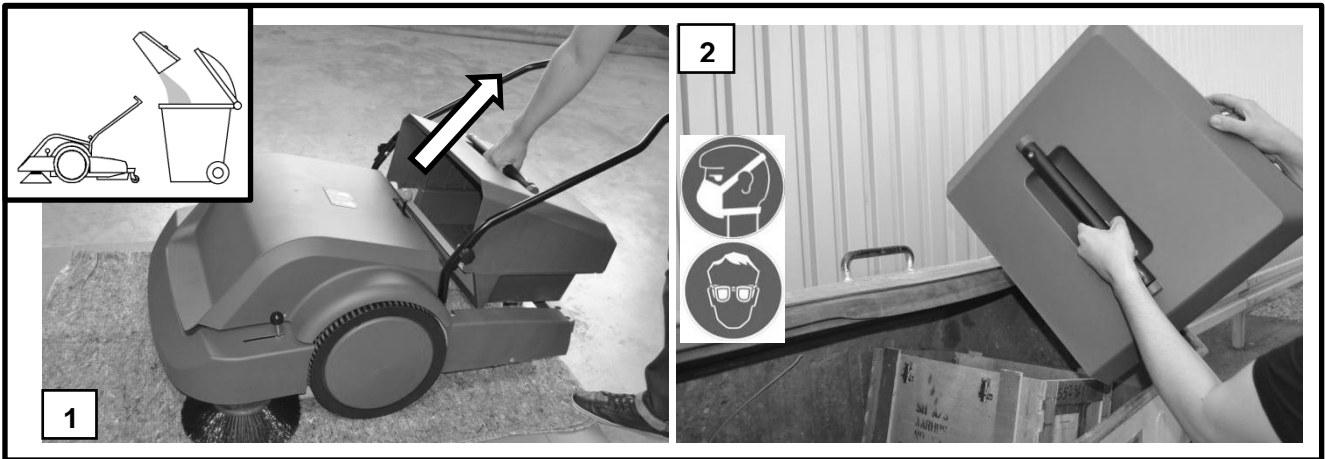
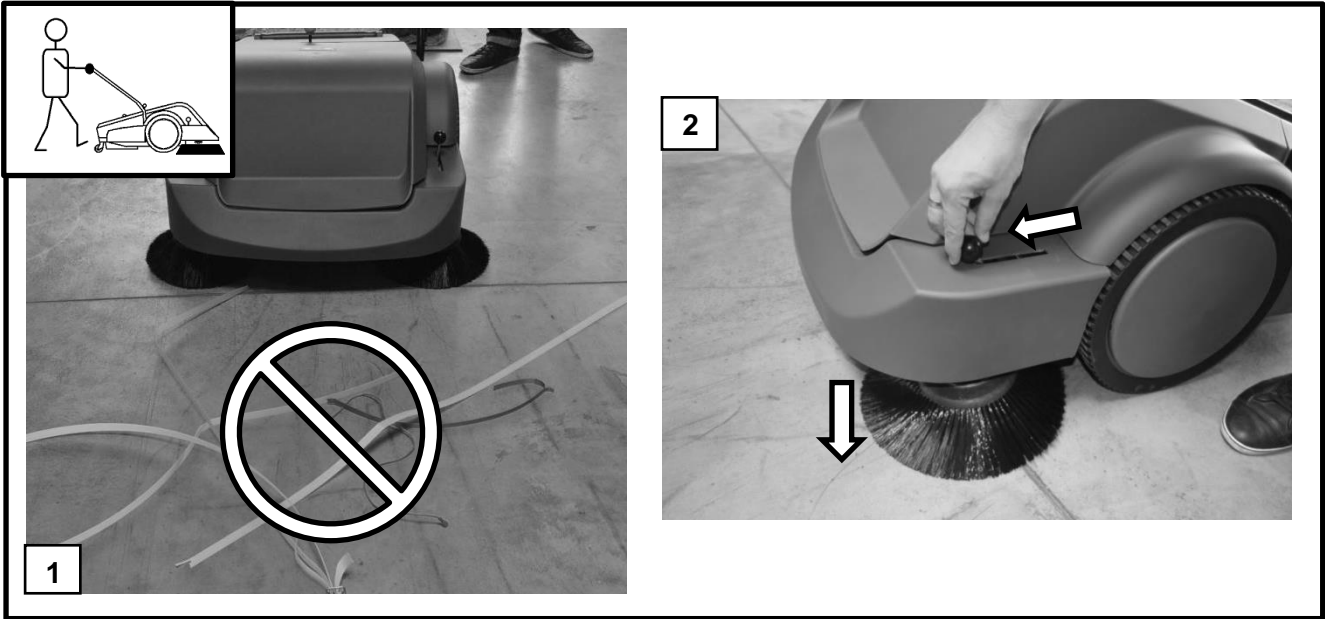

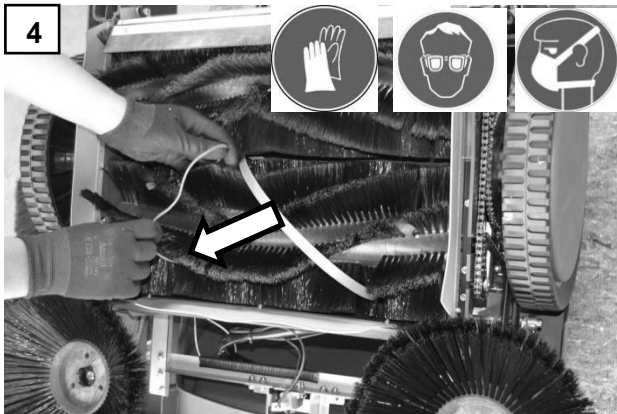
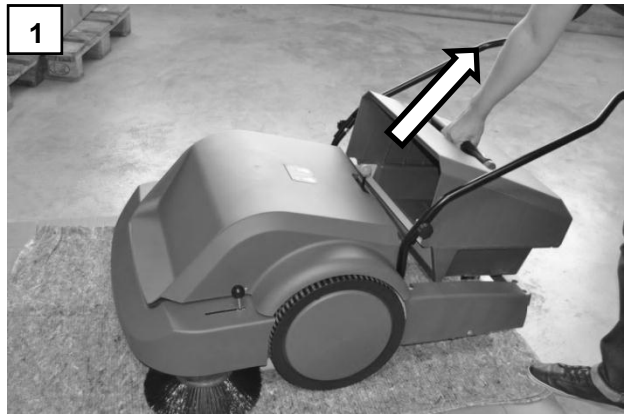
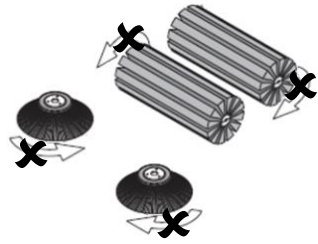
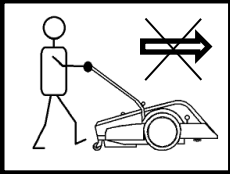

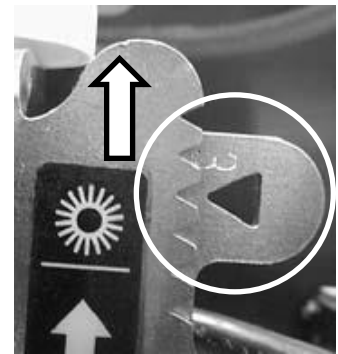
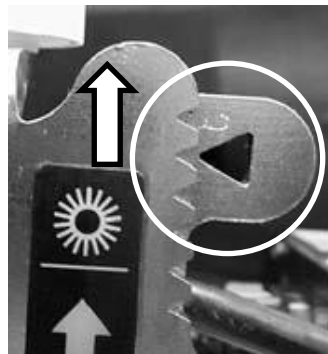
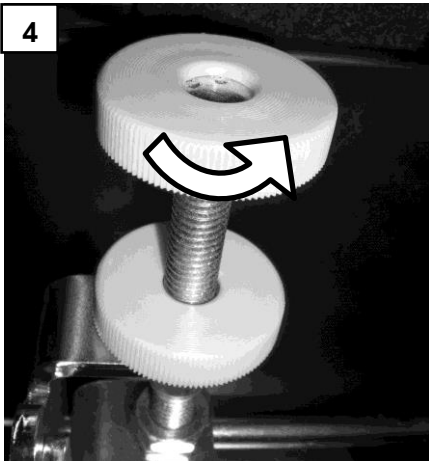
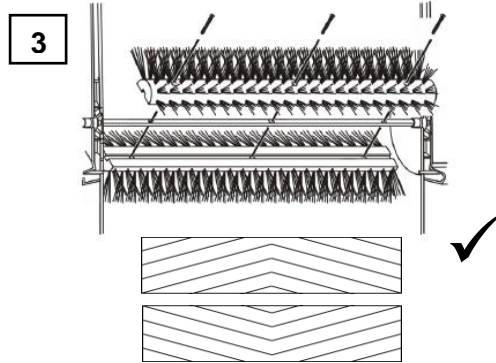
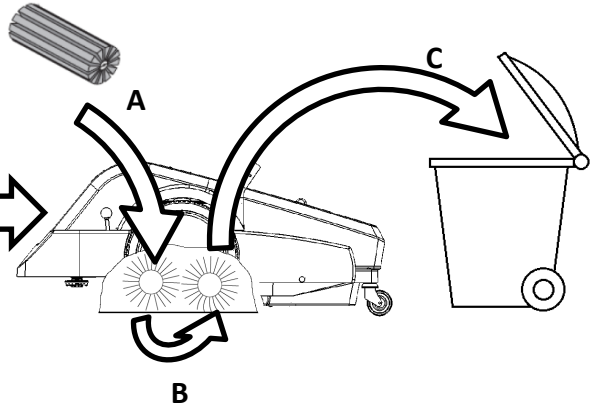
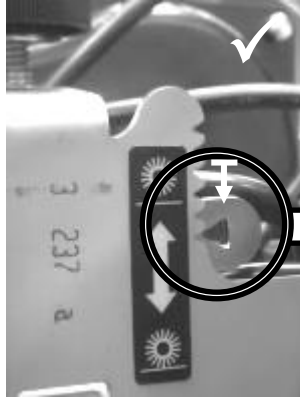
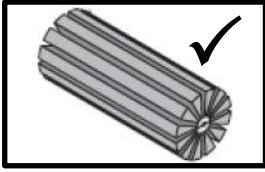

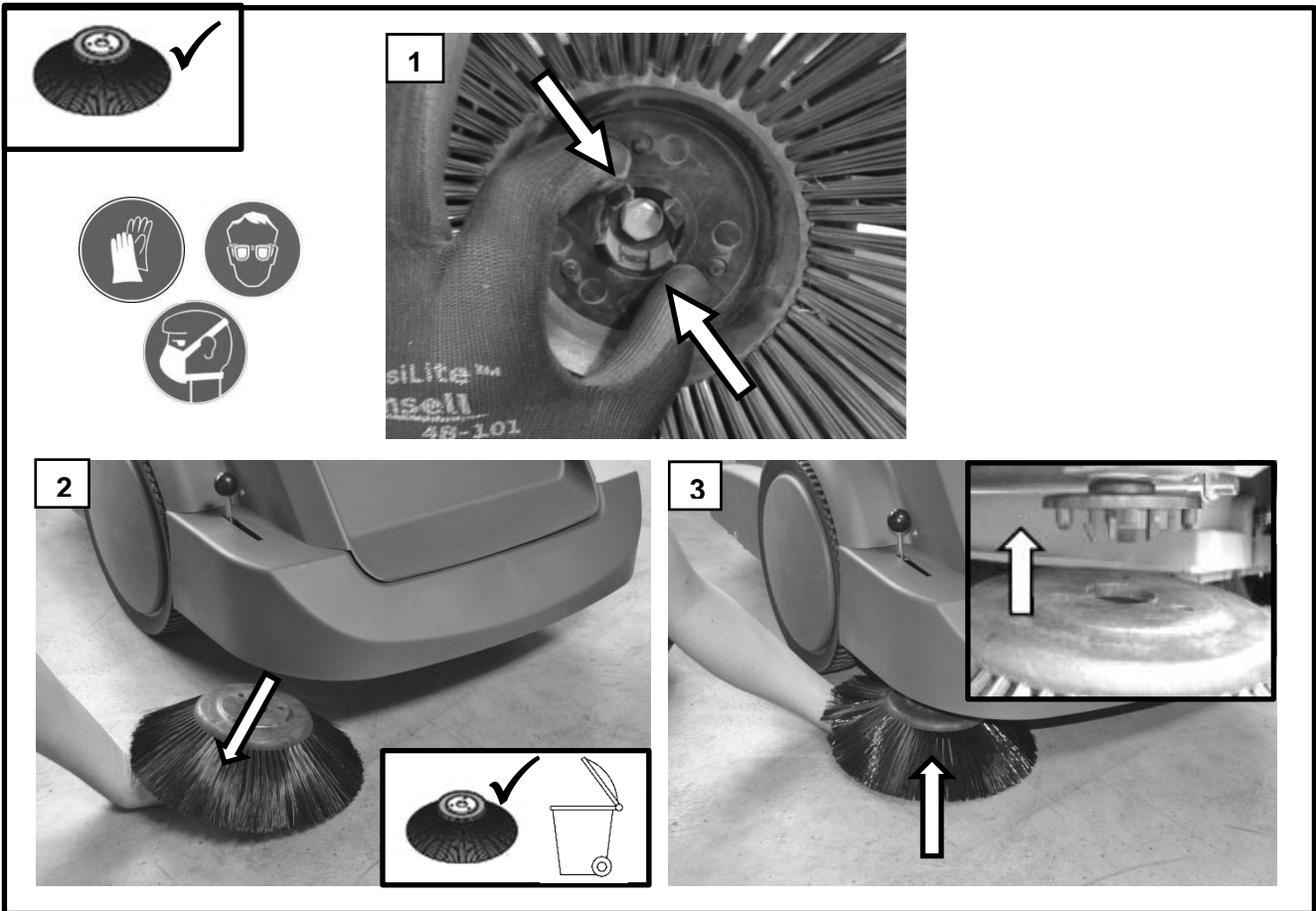

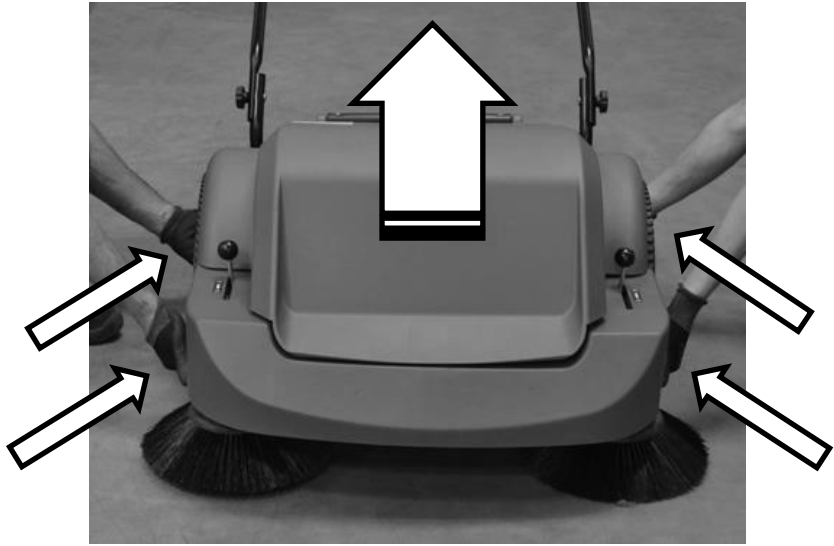
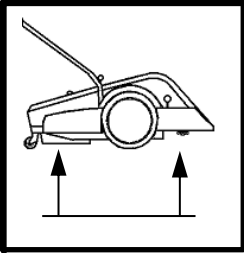

Walk Behind Sweeper

MODEL: XX
MATERIAL NO.: XXXXXXX
SERIAL NUMBER: XX XXX XXX
DC: XXXX
WEIGHT-NET: 32 kg

TENNANT COMPANY
701 North Lilac Drive
P.O. Box 1452
Minneapolis, MN 55440 USA
1-800-553-8033
www.tennantco.com

Made in Germany

Fig. 1 – Cover and Handle Group

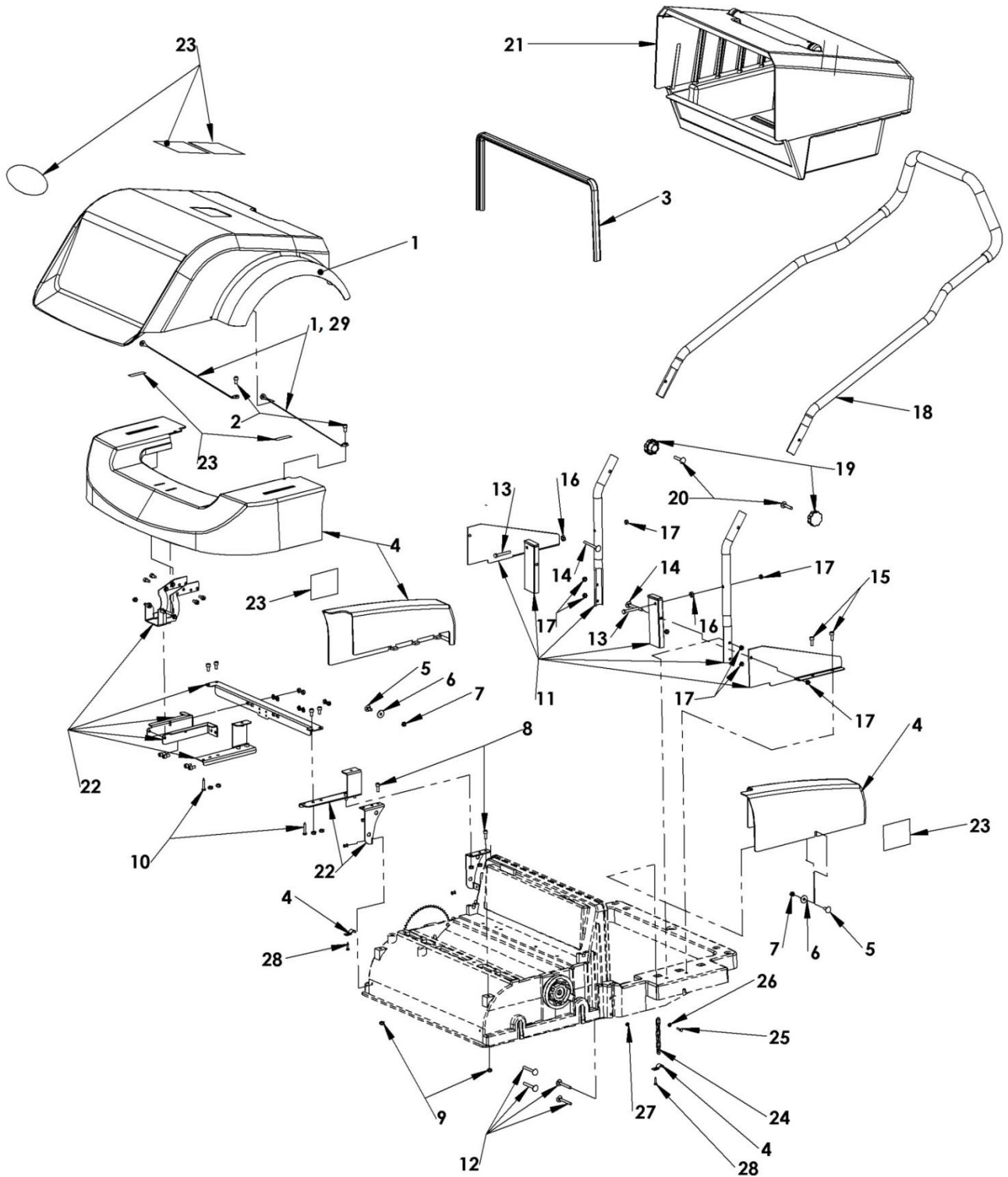

Fig. 1 – Cover and Handle Group

Ref.	Part No.	Description	Qty.	
▽	1	9010109	Front Cover Kit,NG (Includes Front Cover Qty 1, Cable Qty 2, Warning Lable Qty 1 & Mounting Hardware)	1
▲	2	N/A	Screw, Soc, M6x1x12	2
	3	9010009 ●	Seal Kit (Includes Hopper Seal Qty 1, Fan Seal Qty1, Edging Qty 2, Battery Strap Qty 1, Strap Bracket Qty1)	1
▽	4	9010110	Shroud Kit, HG(Including Front Shroud Qty 1, lh Rear Cover Qty 1, rh Rear Cover Qty 1, Clamp Qty 2 & Mounting Hardware)	1
▲	5	N/A	Bolt, Carriage M6x1x16	2
▲	6	N/A	Washer, Flat, M6 x 20	2
▲	7	N/A	Nut, Hex, Lock, M6x1, NL	2
▲	8	N/A	Screw, Soc, M6x1x16	2
▲	9	N/A	Nut, Hex, Lock, M6x1, NL	2
▲	10	N/A	Screw, Pan, 5x30 TCUT	2
▽	11	9010113	Handle Bracket Kit (Includes lh Handle Bracket Qty 1, rh Handle Bracket Qty 1, Square Tube Qty 2, lh Support Qty 1,rh Support Qty 1 & Mounting Hardware)	1
▲	12	N/A	Bolt, Carriage, M6x1x50	4
▲	13	N/A	Screw, Hex, M6x1x45	2
▲	14	N/A	Bolt, Carriage, M6x1x60	2
▲	15	N/A	Screw, Soc, M6x1x16	4
▲	16	N/A	Nut, Hex, Jam, M8x1.25	2
▲	17	N/A	Nut, Hex, Lock, M6x1, NL	12
	18	9009993 ●	Handle, Kit (Includes Soft Grip)	1
▽	19	9009994 ●	Handle Knob Kit	1
▲	20	N/A	Bolt, Carriage, M6x1x35	2
	21	9010013	Hopper, Kit , NG	1
	22	9010125	Shroud Mounting Kit (Includes Hinge Qty 1, Switch Actuator Qty 1, Brackets Qty 5 & Mounting Hardware)	1
	23	9010102 ●	Label Kit (Includes Logo Nobles Qty 1, Logo Scout Qty 2, Label Warning NA Qty 1, Label Warning EU Qty 1, Label Side Brush Qty 2, Label Main Brush Qty 1, Label Shaker Qty 1)	1
▽	24	9009647 ●	Strap Kit, Static (Includes Static Chain & Mounting Hardware)	1
▲	25	N/A	Screw, Hex, M4x0,75x16	1
▲	26	N/A	Washer, Flat M4	1
▲	27	N/A	Nut, Hex, Lock M4	1
▲	28	N/A	Screw, Pan, 3,5x13 TCUT	2
	29	9013559	Cover Cable Kit (Includes cables Qty 2 and mounting hardware)	1

▽ ASSEMBLY

▲ INCLUDED IN ASSEMBLY

● RECOMMENDED STOCK ITEM

N/A Not Available Separately. Local Purchase.

Fig. 2 – Main Brush and Wheel Group

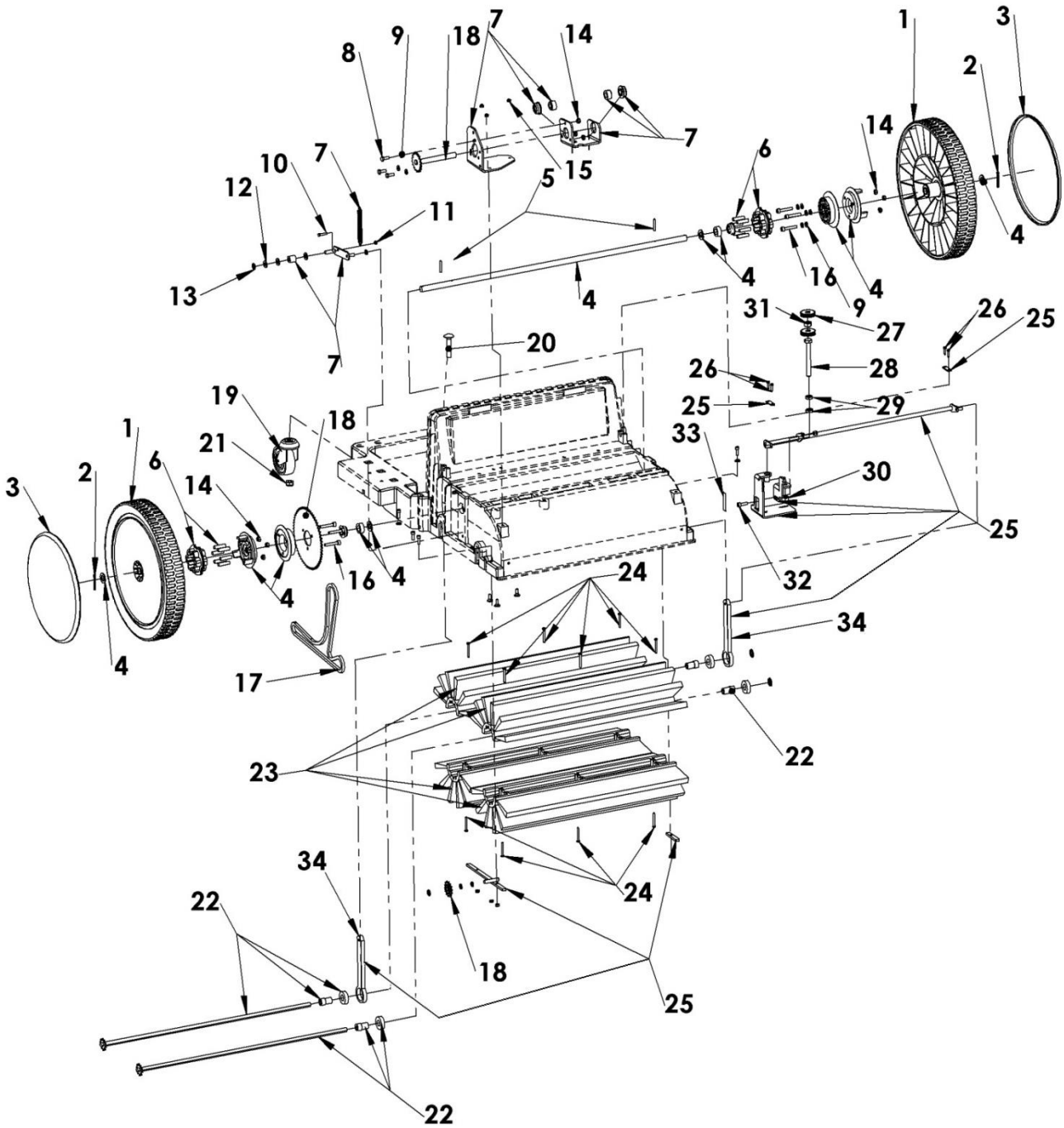

Fig. 2 – Main Brush and Wheel Group

Ref.	Part No.	Description	Qty.
▽	1	9010018 ● Wheel Kit (Includes Wheel Qty 1, Bearings Qty 2 & Mounting Hardware)	2
▲	2	N/A Cotter pin 3,2x40	2
	3	9010020 ● Hub Cap Kit, NG (Includes Qty 2)	1
▽	4	9010024 Drive Axle Kit (Including Shaft Qty 1, Bearings Qty 2, Driver Outside Qty 2, Driver Inside Qty 2, Felt Washer Qty 4 & Mounting Hardware)	1
▲	5	N/A Cylinder pin Ø4x30	2
	6	9010112 ● Wheel Bearing Kit	1
▽	7	9010117 Main Brush Chain Tensioner Kit (Includes Axle Bracket Qty 1, Tensioning Arm Qty 1, Spring Qty 1, Chain Roller Qty 1 & Mounting Hardware)	1
▲	8	N/A Screw, Hex, M6x1x16	3
▲	9	N/A Washer, Flat, M6	9
▲	10	N/A Screw, Hex, M4x0.7x20	1
▲	11	N/A Nut, Hex, Lock, M4x0.7, NL	1
▲	12	N/A Washer, Flat, M8	3
▲	13	N/A Retainment Ring D=8	1
▲	14	N/A Nut, Hex, Lock, M6x1, NL	9
▲	15	N/A Nut, Hex, Lock, M5x0.8, NL	5
▲	16	N/A Screw, Soc, M6x1x35	6
	17	9010022 ● Main Brush Chain	1
	18	9010023 Spocket Kit (Includes Sprocket Axle Qty 1, Drive Sprocket Qty 1 , Deflection Sprocket Qty 1 & Mounting Hardware)	1
▽	19	9010021 ● Caster Kit (Includes Mounting Hardware)	1
▲	20	N/A Bolt, Carriage, M10x1.5x55	1
▲	21	N/A Nut, Hex, Lock, M10x1.5, NL	1
	22	9010111 Main Brush Axle Kit (Includes Axle Qty 1, Bushing Qty 2, Bearing Qty 2, Square 8 Retainment Ring Qty 1	2
▽	23	9009995 ● Main Brush Kit (Includes Brush Half Shell Qty 2 & Mounting Hardware)	2
▲	24	N/A Screw, Pan, 3.9x38, TCUT	12
▽	25	9010119 Main Brush Adjustment Kit (Includes Adjustment Axle Qty 1, Fixing Brackets Qty 2, Charger Mounting Bracket Qty 1, Pointer Qty 1, Main Brush Lever Qty 2 & Mounting Hardware)	1
▲	26	N/A Screw, Pan, 3.5x13, TCUT	4
▽	27	9010011 ● Knob Kit (Includes Black Balls M8 Qty 2, Yellow Balls M8 Qty 1, Knurled Screw M10 Qty 2 & Mounting Material)	1
▲	28	N/A Screw, Hex, M10x1.5x90	1
▲	29	N/A Nut, Hex, Jam, M10x1.5	2
▲	30	N/A Nut, Hex, Lock, M10x1.5, NL	1
▲	31	N/A Nut, Hex, Std, M10x1.5	1
▲	32	N/A Screw, Soc, M6x1x20	1
	33	9010102 ● Label Kit (Includes Logo Nobles Qty 1, Logo Scout Qty 2, Label Warning NA Qty 1, Label Warning EU Qty 1, Label Side Brush Qty 2, Label Main Brush Qty 1, Label Shaker Qty 1)	1
	34	9013459 Adjustment Link Kit (Includes Brush Adjuster Lever Qty 2)	1

▽ ASSEMBLY

▲ INCLUDED IN ASSEMBLY

● RECOMMENDED STOCK ITEM

N/A Not Available Separately. Local Purchase.

Fig. 3 – Side Brush Group

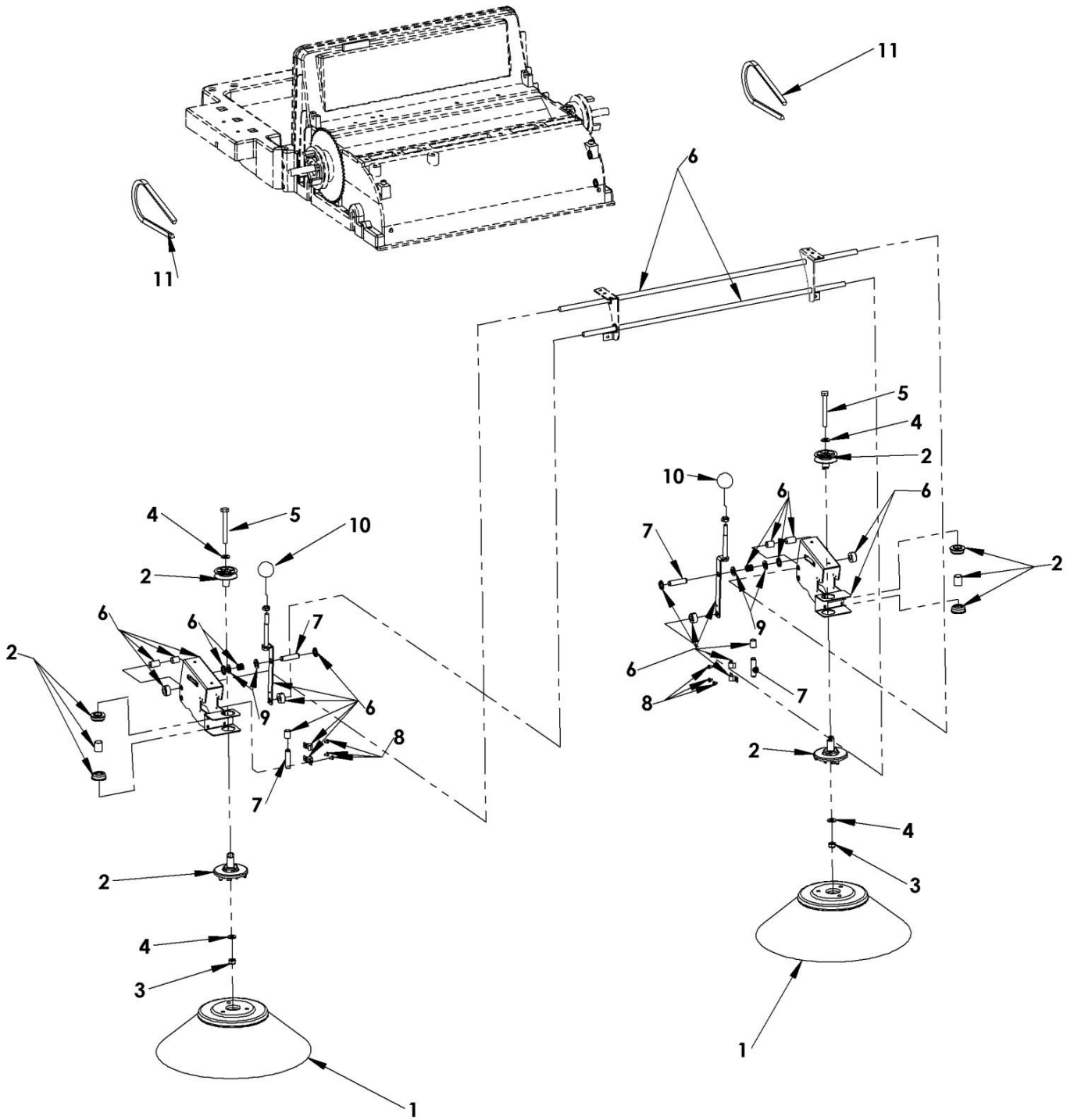

Fig. 3 – Side Brush Group

Ref.	Part No.	Description	Qty.
	1	9009997 ● Side Brush Pack Qty 1	2
▽	2	9010121 ● Side Brush Pulley Kit (Includes Pulley Kit Qty 1, Bearings Qty 2, Bushing Qty 1 & Mounting Hardware)	2
▲	3	N/A Nut, Hex, Lock, M8x1.25, NL	2
▲	4	N/A Washer, Flat, M8	4
▲	5	N/A Screw, Hex, M8x1.25x70	2
▽	6	9010026 Side Brush Lift Kit (Includes Adjustment Lever Qty 2, rh Bracket Qty 1, lh Bracket Qty 1, Bearings Qty 4, Spring Qty 2, Axle 1 Qty 1, Axle 2 Qty 2 & Mounting Hardware)	1
▲	7	N/A Cylinder Pin 10x40	4
▲	8	N/A Screw, Pan, 3.9x6.5 TCUT	6
▲	9	N/A Washer, Flat, M10	4
	10	9010011 ● Knob Kit (Includes Black Balls M8 Qty 2, Yellow Balls M8 Qty 1, Knurled Screw M10 Qty 2 & Mounting Material)	1
	11	9010025 ● Belt, Side Brush	2

▽ ASSEMBLY

▲ INCLUDED IN ASSEMBLY

● RECOMMENDED STOCK ITEM

N/A Not Available Separately. Local Purchase.