



# UC452523 - Bin Top Utility Carts Large Bin Top Utility Cart 5" Casters 45" x 25" - Gray



Item Number:  
**UC452523**

Case Pack:  
**1 ea**

- Excellent for transporting equipment and heavy loads
- Reduces the potential for items to fall off during transport
- Durable and chemical-resistant polypropylene construction; will not rust, dent, chip or peel
- Convenient knock-down design
- 500 lb capacity
- Useable shelf space is 23.75" x 43.75"
- Shelf is 3.5" deep
- Features two fixed and two swivel casters



## Tech Specs

	US	Metric
<b>Length</b>	45.00 in	114.30 cm
<b>Width</b>	25.00 in	63.50 cm
<b>Height</b>	33.00 in	83.82 cm
<b>Min Temperature</b>	32.00 °F	0.00 °C
<b>Max Temperature</b>	180.00 °F	82.22 °C
<b>Capacity (Weight)</b>	500.00 lb	226.80 kg
<b>Depth of Bin</b>	3.00 in	7.62 cm
<b>Inside Shelf Height</b>	22.25 in	56.52 cm
<b>Material</b>	Polypropylene (PP)	
<b>Country of Origin</b>	China	
<b>Case GTIN</b>	10077838816087	

## Tech Specs

	US	Metric
<b>Case Weight</b>	41.45 lb	18.80 kg
<b>Case Cube</b>	5.82 ft3	0.16 m3
<b>Case Length</b>	38.19 in	97.00 cm
<b>Case Width</b>	9.84 in	24.99 cm
<b>Case Height</b>	26.77 in	68.00 cm
<b>Pallet Case Qty</b>	4	
<b>Pallet Tier</b>	2	
<b>Pallet High</b>	2	
<b>Harmonized Code</b>	940370.8031	
<b>Freight Class</b>	125	

## Related Products

Product	Description	Case		
		Pack	Weight	Cube
<b>Related Products</b>				
<a href="#">UCC4018</a>	Replacement Caster for <a href="#">UC4018</a> & <a href="#">UC4525</a> (Swivel) 5" Caster	1 cs	5.00 lb	0.12 ft³
<a href="#">UCC4525</a>	Replacement Caster for <a href="#">UC4018</a> & <a href="#">UC4525</a> (Fixed) 5" Caster	1 cs	5.00 lb	0.12 ft³

Copyright © 2017 Carlisle FoodService Products. All rights reserved.

# Assembly Instructions: Service Cart

PRODUCT NUMBER: UC4018 & UC4525

## Parts List:

4 Legs, 4 Corners, 2 Shelves  
2 Fixed Casters, 2 Swivel Casters, 1 Handle  
1 Hardware Packet Containing 12 Screws, 16 Bolts,  
16 Lock Washers, 16 Nuts (15mm)

## Tools Needed:

Phillips Screwdriver, Mallet, Wrench

**Assembled  
ServiceCart**



Steps:

1.

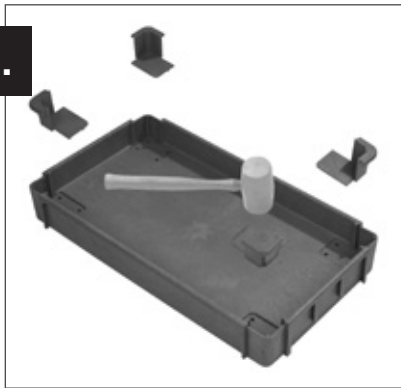

2.



3.



Use 3 screws to secure each leg to frame

4.



5.

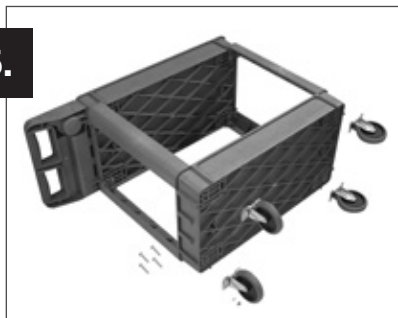

Use 4 bolts, lock washers and nuts to secure legs and casters to frame

**Parts  
Replacement**

